

SSL - Top Load Socket



Series 9159



The 9159 series of Board-to-Board interconnect system allows two PCB's to be mated end-to-end creating strips of LED lighting. Designed specifically for the unique Solid State Lighting (SSL) market requiring coplanar (horizontal-to-horizontal) PCB mating with a 5 Amp current rating in the smallest package available. The top loading socket allows complete PCB's to be replaced in the field without having to disassemble the entire strip of boards. The connector has a two part insulator whereby the top of the connector will slide open allowing the plug connector to be pulled out either vertically or at a slight angle. Once the PCB is replaced, the cover is slid back like a Zero Insertion Force (ZIF) connector to the closed position. The PCB layout is identical to the standard horizontal socket to maintain family commonality at the PCB level.

Additional components in the 9159 product family include:

- SSL - Horizontal Plug; Standard 2-Piece solution (10-9159)
- SSL - Cabled Plug; Supports wire-to-board applications (11-9159)
- SSL - Horizontal Socket; Standard 2-Piece solution (20-9159)
- SSL - Shorting Socket; Two position (58-9159)
- SSL - Retaining Clip; Latches BTB connectors together (80-9159)

APPLICATIONS

- Coplanar PCB mating in SSL products
- LED linear lighting strips
- Application Notes; refer to 201-01-123

FEATURES AND BENEFITS

- Slide open top; allows field reparability at the light fixture level
- Mates with standard horizontal or cabled plug; no need to change any connectors
- 5 Amp current rating; exceeds general market needs
- Gold plated BeCu spring contacts; reliability for harsh environments
- Available in white; supports SSL market preferences

ELECTRICAL

- Current Rating: 5 Amps / Contact
- Voltage Rating: 125 VAC

ENVIRONMENTAL

- Operating Temperature: -40°C to +125°C

MECHANICAL

- Insulator Material: Nylon: VL94VO
- Contact Material: BeCu / Phos Bronze
- Plating: Gold / Tin over Nickel
- Durability: 10 Cycles

HOW TO ORDER

22	9159	XXX	1	01	X	16																																	
Prefix Socket Top Loading	Series	Number of Ways	2 Part PCB Strip Connector	Connector Pitch 01 = 3mm	Color Options	Plating Option																																	
		<table border="1"> <thead> <tr> <th>Code</th> <th>No of Ways</th> <th>Details</th> </tr> </thead> <tbody> <tr> <td>002</td> <td>2</td> <td>Page 25</td> </tr> <tr> <td>003</td> <td>3</td> <td>Page 26</td> </tr> <tr> <td>004</td> <td>4</td> <td>Page 27</td> </tr> <tr> <td>005</td> <td>5</td> <td>Page 28</td> </tr> <tr> <td>006</td> <td>6</td> <td>Page 29</td> </tr> </tbody> </table>	Code	No of Ways	Details	002	2	Page 25	003	3	Page 26	004	4	Page 27	005	5	Page 28	006	6	Page 29			<table border="1"> <thead> <tr> <th>Code</th> <th>Color</th> <th>Application</th> </tr> </thead> <tbody> <tr> <td>0</td> <td>Black</td> <td>Industrial</td> </tr> <tr> <td>1</td> <td>White</td> <td>Lighting</td> </tr> </tbody> </table>	Code	Color	Application	0	Black	Industrial	1	White	Lighting	<table border="1"> <thead> <tr> <th>Code</th> <th>Contact</th> <th>Bracket</th> </tr> </thead> <tbody> <tr> <td>16</td> <td>Gold in Contact Area Tin on Solder Tail</td> <td>Tin all over</td> </tr> </tbody> </table>	Code	Contact	Bracket	16	Gold in Contact Area Tin on Solder Tail	Tin all over
Code	No of Ways	Details																																					
002	2	Page 25																																					
003	3	Page 26																																					
004	4	Page 27																																					
005	5	Page 28																																					
006	6	Page 29																																					
Code	Color	Application																																					
0	Black	Industrial																																					
1	White	Lighting																																					
Code	Contact	Bracket																																					
16	Gold in Contact Area Tin on Solder Tail	Tin all over																																					



SSL - Top Load Socket



Series 9159

SOCKET TOP LOADING 2 WAY 2 PART PCB STRIP CONNECTOR

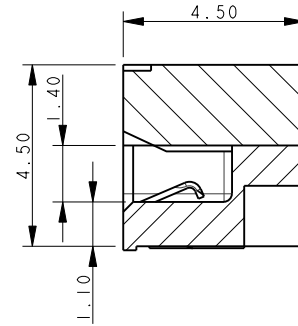
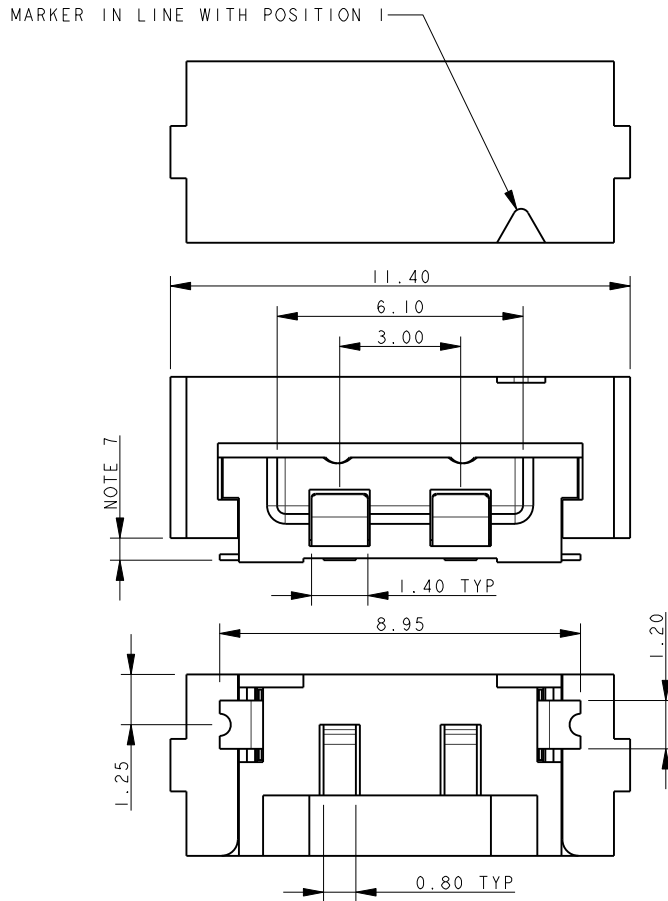

NOTES:

1. FOR MORE INFORMATION REFER TO PRODUCT SPEC 201-01-119.
2. DIMENSIONS ARE REFERENCE DIMENSIONS UNLESS TOLERANCES.
3. INSULATOR MATERIAL: NYLON 46. COLOR REFER TO PAGE 24.
4. CONTACT MATERIAL: COPPER ALLOY, GOLD OVER NICKEL.
5. BRACKETS: COPPER ALLOY, TIN PLATED.
6. OUTLINE OF CONNECTOR.
7. RESTRICTED COMPONENT HEIGHT UNDER CATCH, 2.20MM MAXIMUM.
8. RESTRICTED COMPONENT HEIGHT UNDER CATCH, 0.40MM MAXIMUM.
9. PACKING TAPE AND REEL, QUANTITY 1400 PER REEL.

2 WAY PCB BOARD LAYOUT

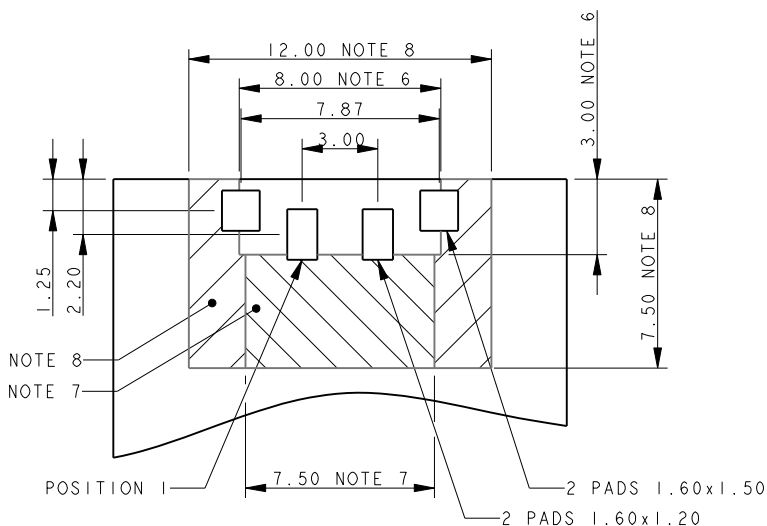

PACKING DETAILS

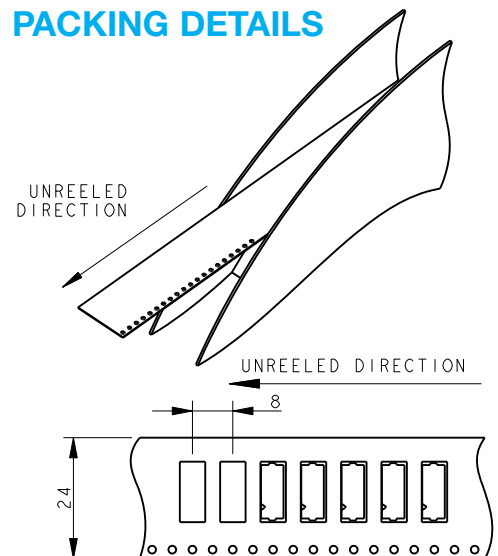

SSL - Top Load Socket

Series 9159



SOCKET TOP LOADING 3 WAY 2 PART PCB STRIP CONNECTOR

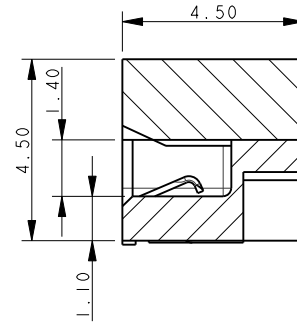
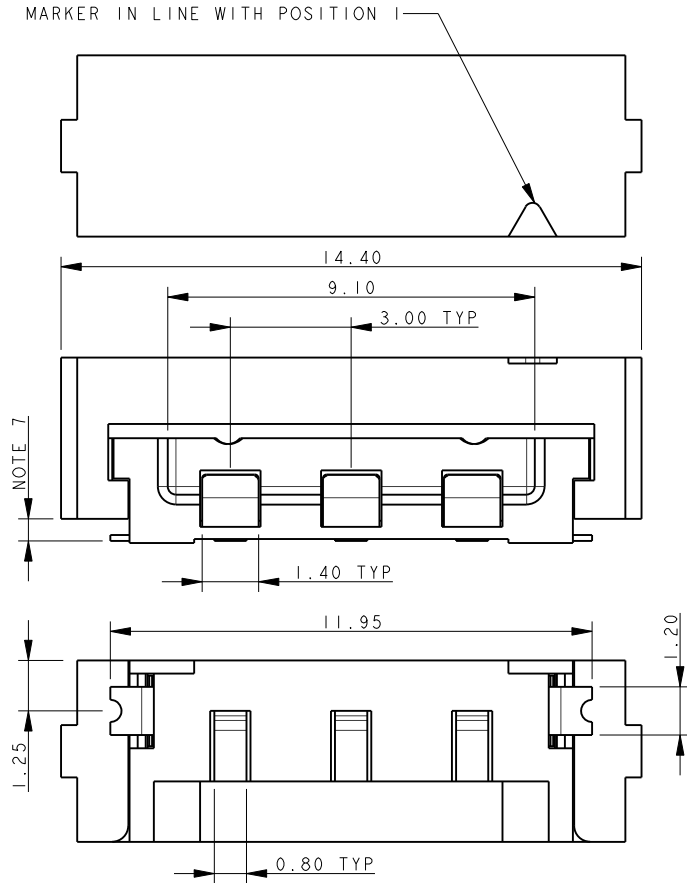

- NOTES:
1. FOR MORE INFORMATION REFER TO PRODUCT SPEC 201-01-119.
 2. DIMENSIONS ARE REFERENCE DIMENSIONS UNLESS TOLERANCES.
 3. INSULATOR MATERIAL: NYLON 46. COLOR REFER TO PAGE 24.
 4. CONTACT MATERIAL: COPPER ALLOY, GOLD OVER NICKEL.
 5. BRACKETS: COPPER ALLOY, TIN PLATED.
 6. OUTLINE OF CONNECTOR.
 7. RESTRICTED COMPONENT HEIGHT UNDER CATCH, 2.20MM MAXIMUM.
 8. RESTRICTED COMPONENT HEIGHT UNDER CATCH, 0.40MM MAXIMUM.
 9. PACKING TAPE AND REEL, QUANTITY 1400 PER REEL.

3 WAY PCB BOARD LAYOUT

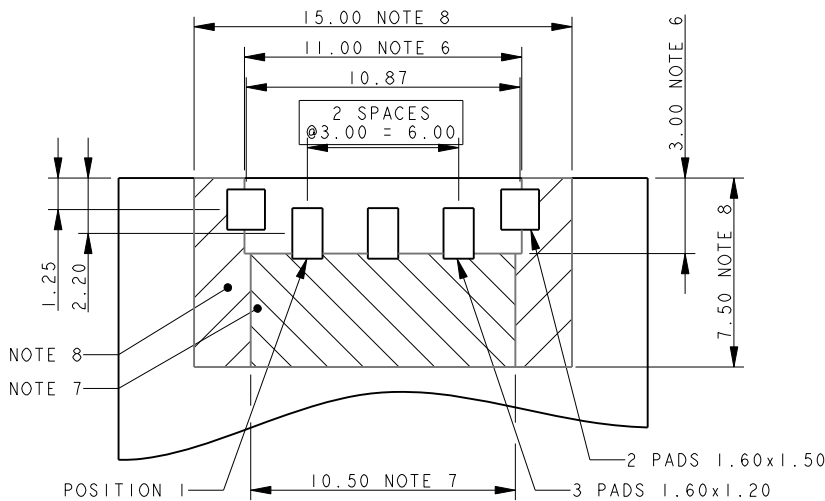

PACKING DETAILS

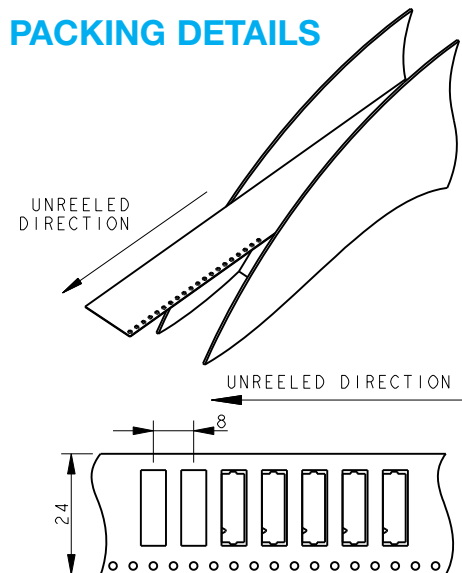

SSL - Top Load Socket



Series 9159

SOCKET TOP LOADING 4 WAY 2 PART PCB STRIP CONNECTOR

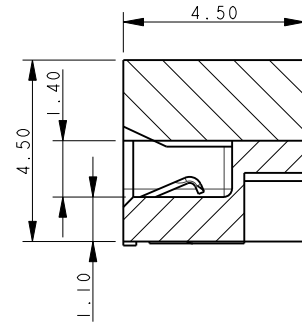
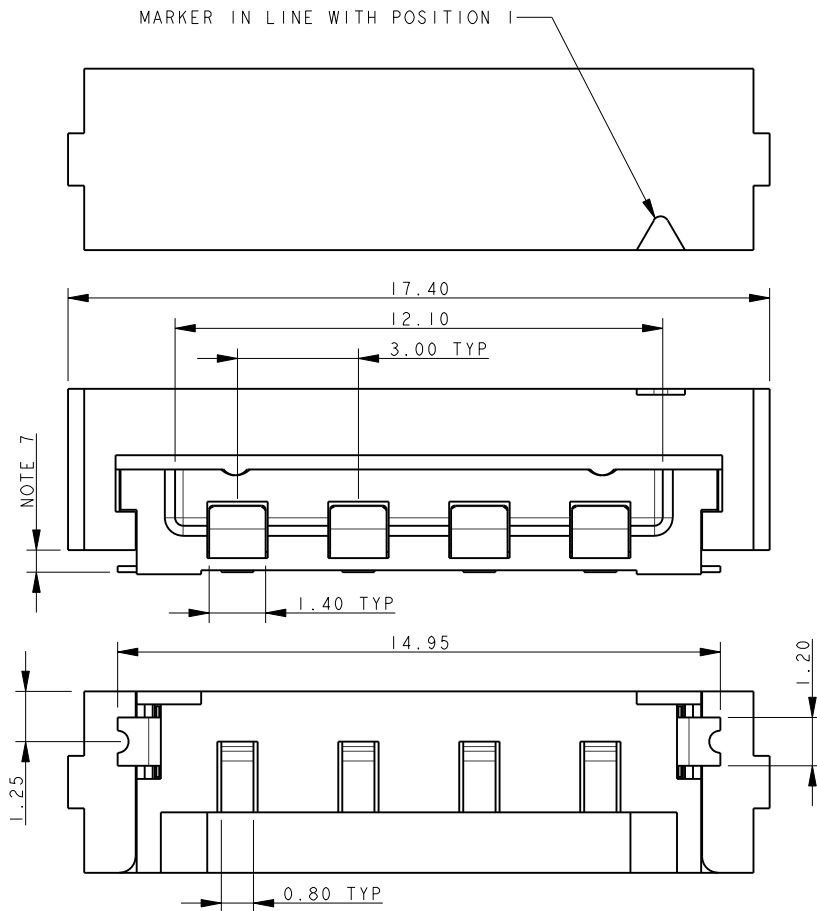

NOTES:

1. FOR MORE INFORMATION REFER TO PRODUCT SPEC 201-01-119.
2. DIMENSIONS ARE REFERENCE DIMENSIONS UNLESS TOLERANCES.
3. INSULATOR MATERIAL: NYLON 46. COLOR REFER TO PAGE 24.
4. CONTACT MATERIAL: COPPER ALLOY, GOLD OVER NICKEL.
5. BRACKETS: COPPER ALLOY, TIN PLATED.
6. OUTLINE OF CONNECTOR.
7. RESTRICTED COMPONENT HEIGHT UNDER CATCH, 2.20MM MAXIMUM.
8. RESTRICTED COMPONENT HEIGHT UNDER CATCH, 0.40MM MAXIMUM.
9. PACKING TAPE AND REEL, QUANTITY 1400 PER REEL.

4 WAY PCB BOARD LAYOUT

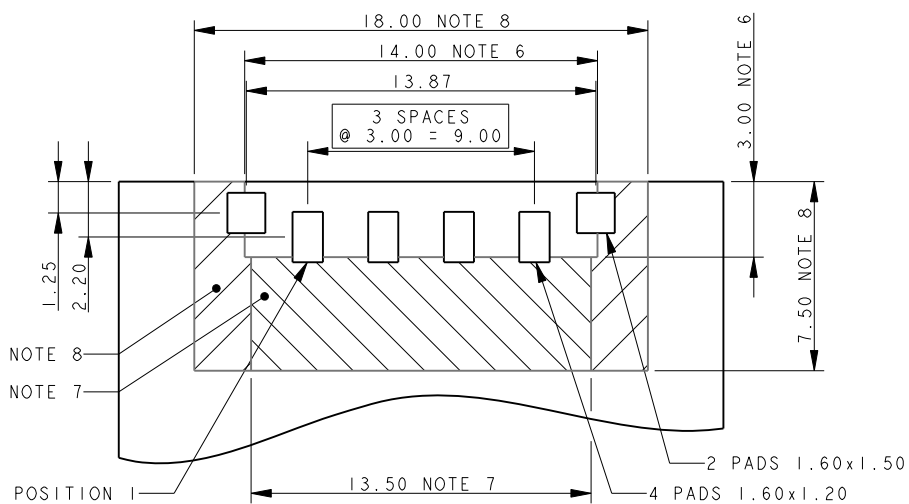

PACKING DETAILS

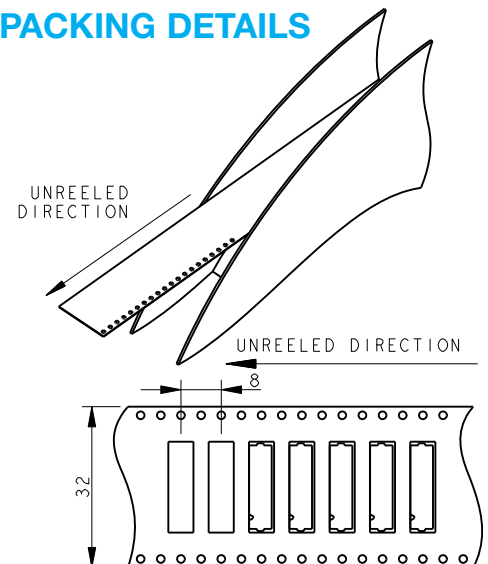

SSL - Top Load Socket

Series 9159



SOCKET TOP LOADING 5 WAY 2 PART PCB STRIP CONNECTOR

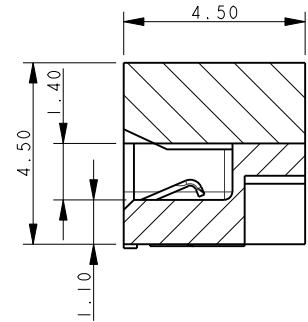
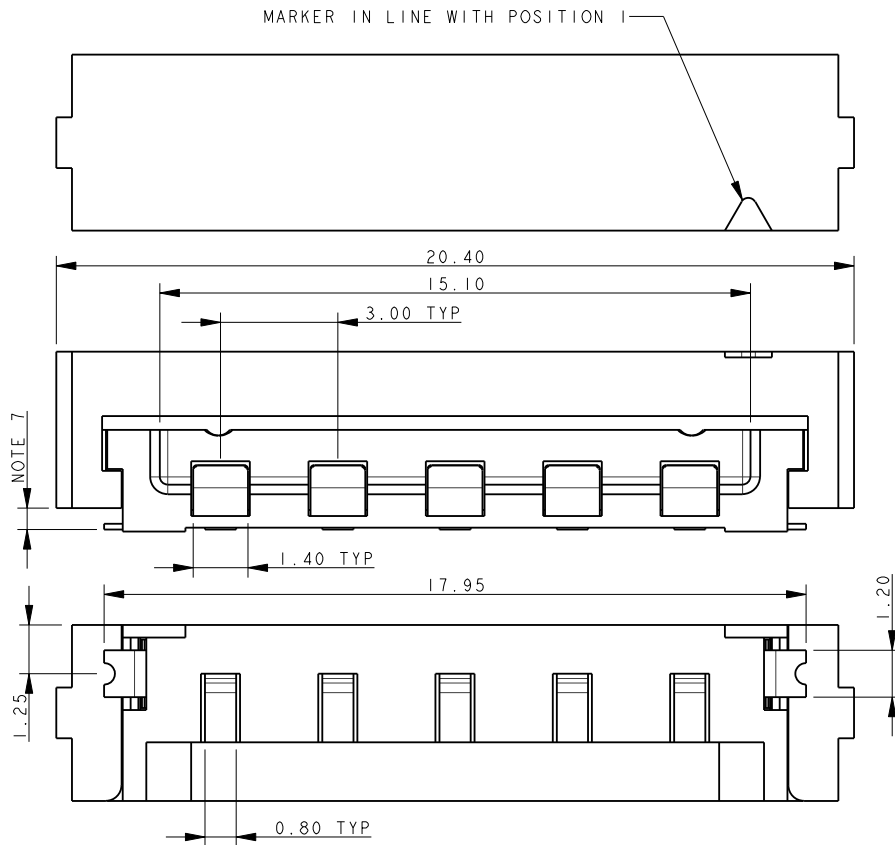

NOTES:

1. FOR MORE INFORMATION REFER TO PRODUCT SPEC 201-01-119.
2. DIMENSIONS ARE REFERENCE DIMENSIONS UNLESS TOLERANCES.
3. INSULATOR MATERIAL: NYLON 46. COLOR REFER TO PAGE 24.
4. CONTACT MATERIAL: COPPER ALLOY, GOLD OVER NICKEL.
5. BRACKETS: COPPER ALLOY, TIN PLATED.
6. OUTLINE OF CONNECTOR.
7. RESTRICTED COMPONENT HEIGHT UNDER CATCH, 2.20MM MAXIMUM.
8. RESTRICTED COMPONENT HEIGHT UNDER CATCH, 0.40MM MAXIMUM.
9. PACKING TAPE AND REEL, QUANTITY 1400 PER REEL.

5 WAY PCB BOARD LAYOUT

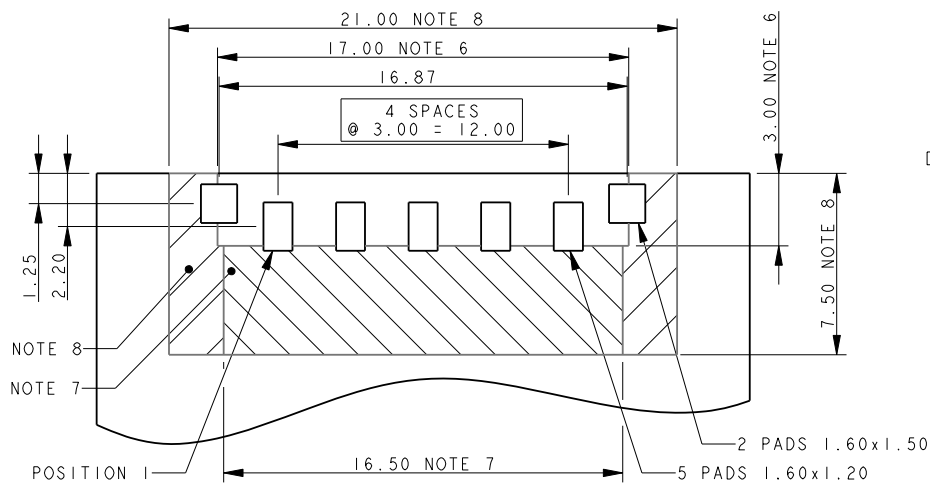

PACKING DETAILS

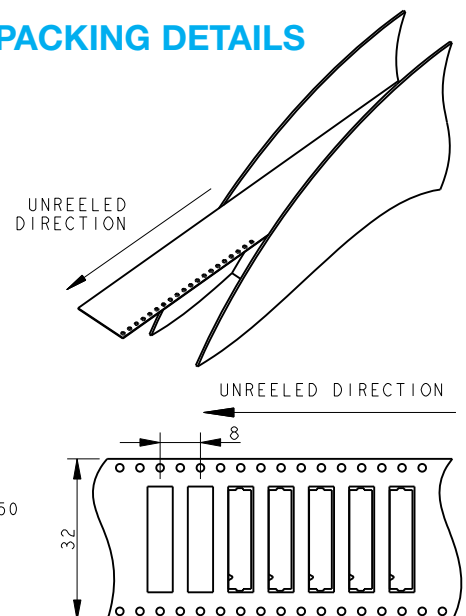

SSL - Top Load Socket



Series 9159

SOCKET TOP LOADING 6 WAY 2 PART PCB STRIP CONNECTOR

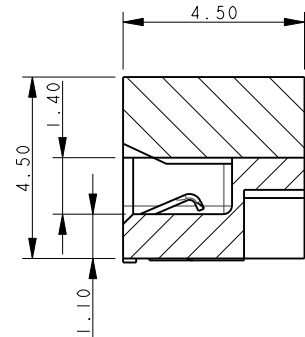
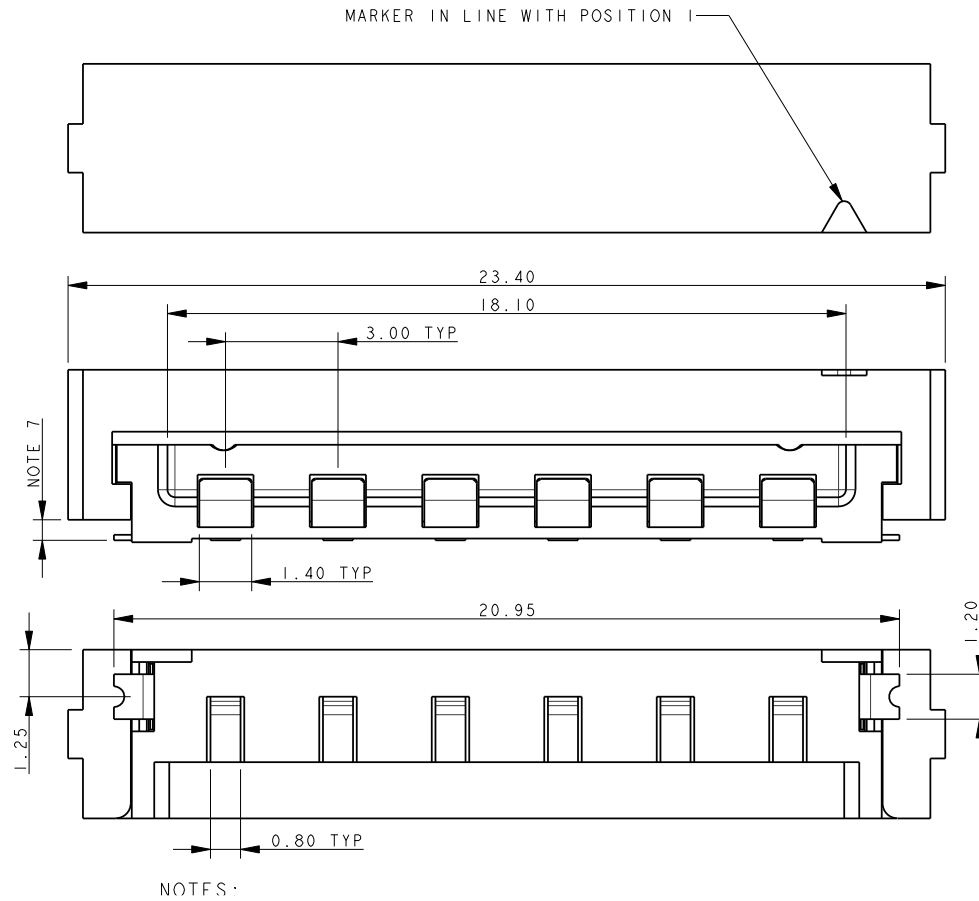

NOTES:

1. FOR MORE INFORMATION REFER TO PRODUCT SPEC 201-01-119.
2. DIMENSIONS ARE REFERENCE DIMENSIONS UNLESS TOLERANCES.
3. INSULATOR MATERIAL: NYLON 46. COLOR REFER TO PAGE 24.
4. CONTACT MATERIAL: COPPER ALLOY, GOLD OVER NICKEL.
5. BRACKETS: COPPER ALLOY, TIN PLATED.
6. OUTLINE OF CONNECTOR.
7. RESTRICTED COMPONENT HEIGHT UNDER CATCH, 2.20MM MAXIMUM.
8. RESTRICTED COMPONENT HEIGHT UNDER CATCH, 0.40MM MAXIMUM.
9. PACKING TAPE AND REEL, QUANTITY 1400 PER REEL.

6 WAY PCB BOARD LAYOUT

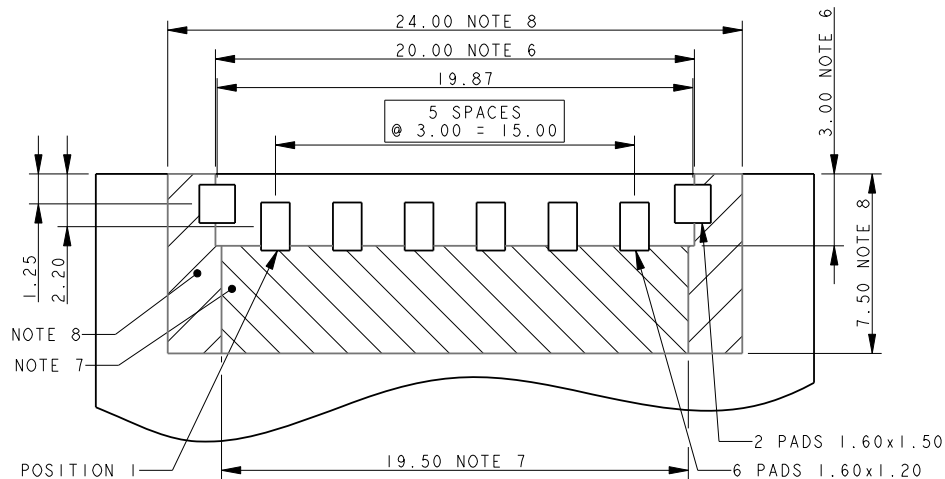

PACKING DETAILS

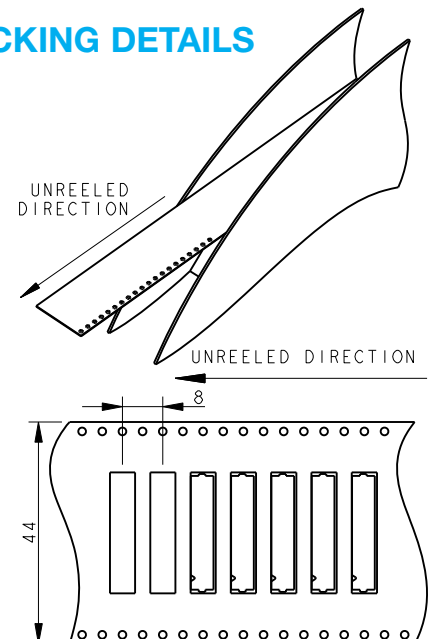

SSL - Top Load Socket

Series 9159



CONNECTOR ASSEMBLY



COVER FORWARD (LOCKED)



COVER SLID BACK



DROP PCB ASSEMBLY ONTO MATING CONNECTORS

